

Product Manual

HPW - OC01 - BLK

Elevate Your Work Experience!



HyperWork
Sleek

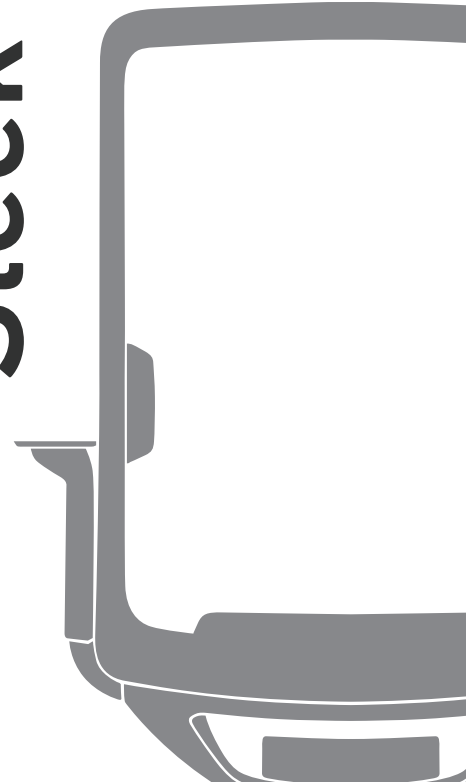

HyperWork Sleek

Installation instructions

Model: HPW - 0C01 - BLK

PARTS LIST



Foam Seat x 1

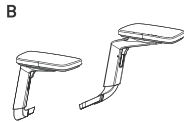

Arms x 1

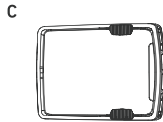

Back x 1

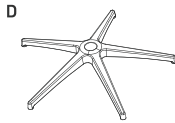

Nylon Foot x 1

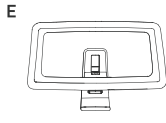

Headrest x 1*

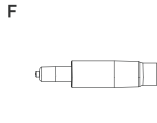

Piston x 1

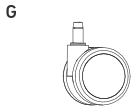

Wheel x 5

**Headrest is optional accessory*

LIST OF SCREWS



1

M6*25mm x 4



2

M6*70mm x 2



3

4mm x 1



4

M6*25mm x 2



5

ST4*16mm x 2



6

5mm x 1

INSTALLATION STEP

Step 1

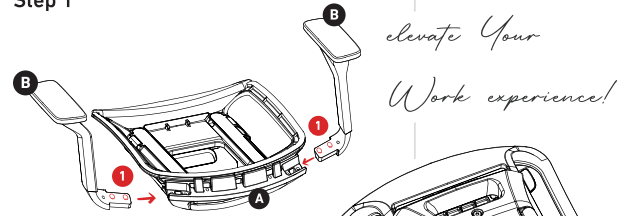

*elevate Your
Work experience!*

Step 2

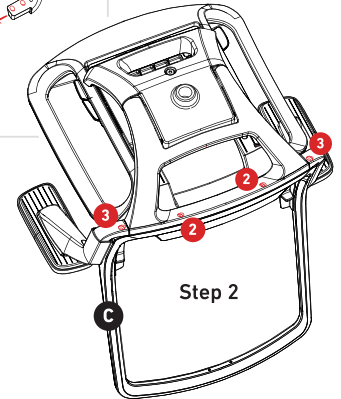

Step 4

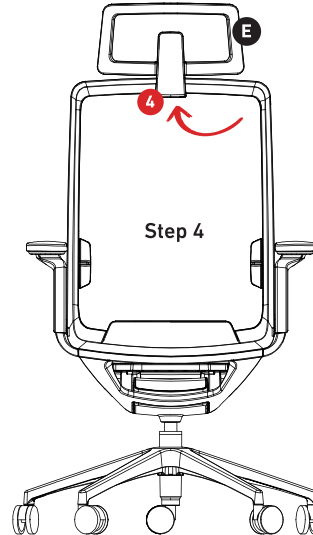

Step 3

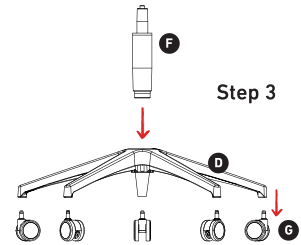

DANH SÁCH LINH KIỆN

A



Mâm ghế x 1

B

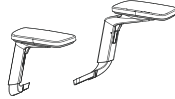

Tay ghế x 1

C



Tựa lưng x 1

D

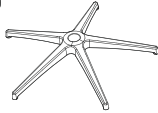

Chân ghế x 1

E

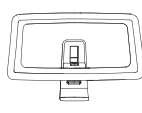

Tựa đầu x 1*

F



Piston x 1



G





Bánh xe x 5

*Tựa đầu là phụ kiện tùy chọn

ỐC VÀ DỤNG CỤ LẮP

	M6*25mm x 4
	M6*70mm x 2
	4mm x 1

	M6*25mm x 2
	ST4*16mm x 2
	5mm x 1

CÁC BƯỚC LẮP ĐẶT

Bước 1

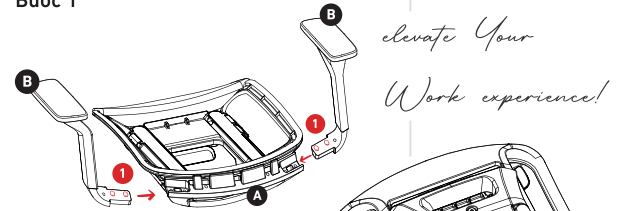

Bước 2

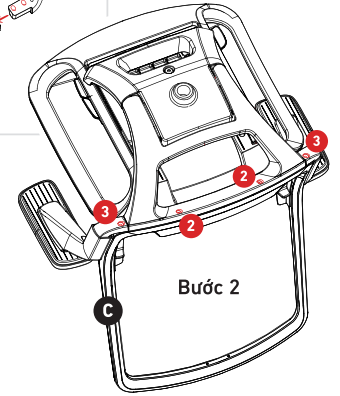

Bước 4

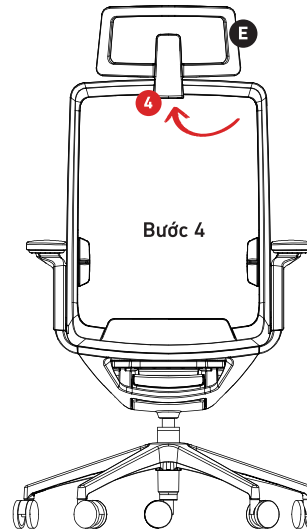

Bước 3

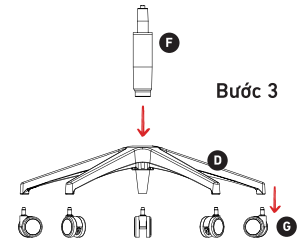

SEAT HEIGHT BUTTON | ĐIỀU CHỈNH ĐỘ CAO



Right Front Button
Nút gạt phía trước bên phải



Increase | Tăng chiều cao ghế
Lift the button and slightly stand up |
Gạt nút và đứng dậy



Reduce | Giảm chiều cao ghế
Lift the button and use your own body weight to lower the chair
Gạt nút và ngồi xuống mồm ghế

**Your feet should flat on the floor | Chiều cao ghế phù hợp là khi lòng bàn chân đặt phẳng hoàn toàn trên mặt đất khi ngồi*

SEAT BACKREST TILT LOCK | KHÓA NGÀ LƯNG



Lift this button up to unlock the feature recline to your desired position, lift this button down to lock the chair back position in place.

Gạt nút này lên để mở khóa tính năng, ngả lưng đến vị trí bạn mong muốn, gạt nút này xuống để khóa cố định vị trí lưng.



Button on the left side
Nút gạt ở bên cạnh trái của ghế

ADJUST SEAT PLATE POSITION | ĐIỀU CHỈNH VỊ TRÍ MÂM GHẾ



Do it while sitting on the chair, lift the button to unlock, then slide the seat plate to the desired position

Thực hiện khi đang ngồi trên ghế, gạt nút để mở khóa sau đó trượt mâm ghế đến vị trí mong muốn



Use the rear right switch
Sử dụng nút gạt phía sau bên phải

TILT ELASTIC AJUSTMENT | ĐIỀU CHỈNH KHÁNG LỰC



Use the included tool kit to tighten the screws under the mechanism system

Twist clockwise: Softer the back rest

Twist counterclockwise: Harder the back rest

Sử dụng bộ dụng cụ đi kèm để vặn con ốc ở dưới mâm ghế như trong hình

Vặn xuôi chiều kim đồng hồ để ngả ghế mềm hơn

Vặn ngược chiều kim đồng hồ để ngả ghế cứng hơn



ARM REST FUNCTION | KÊ TAY



Slide arm rest to forward or backward
inward or outward

*Kê tay có thể điều chỉnh tiến - lùi, lên - xuống
bằng thao tác trượt*



LUMBAR SUPPORT | TỤA LƯNG



Slide lumbar support on the back to your
desired position

*Vị trí tựa lưng có thể điều chỉnh bằng cách gạt 2 thanh
trượt ở phần lưng ghế lên xuống đến vị trí phù hợp
với chiều cao và sở thích của bạn*

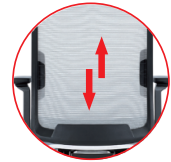

ARM REST FUNCTION | KÊ TAY

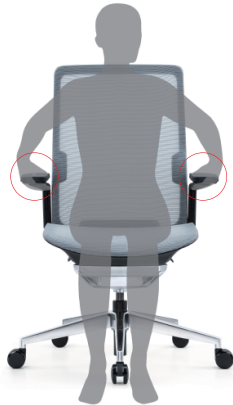

Grab front end of arm rest and tilt it to left or right

*Xoay góc kê tay bằng cách nắm lấy đầu phía
trước và xoay sang trái hoặc phải*

Press the button under arm rest to lower
or raise height

*Tăng, giảm chiều cao kê tay bằng cách bấm
vào nút phía dưới và kéo lên hoặc hạ xuống*



HEADREST | TỤA ĐẦU



The headrest can be adjusted up and down and
change the tilt angle

*Tựa đầu có thể điều chỉnh lên xuống và thay đổi
các góc nghiêng*





HYPERWORK